

Heavy Duty CNC Turning Lathes  
**PROTURN 90/100**

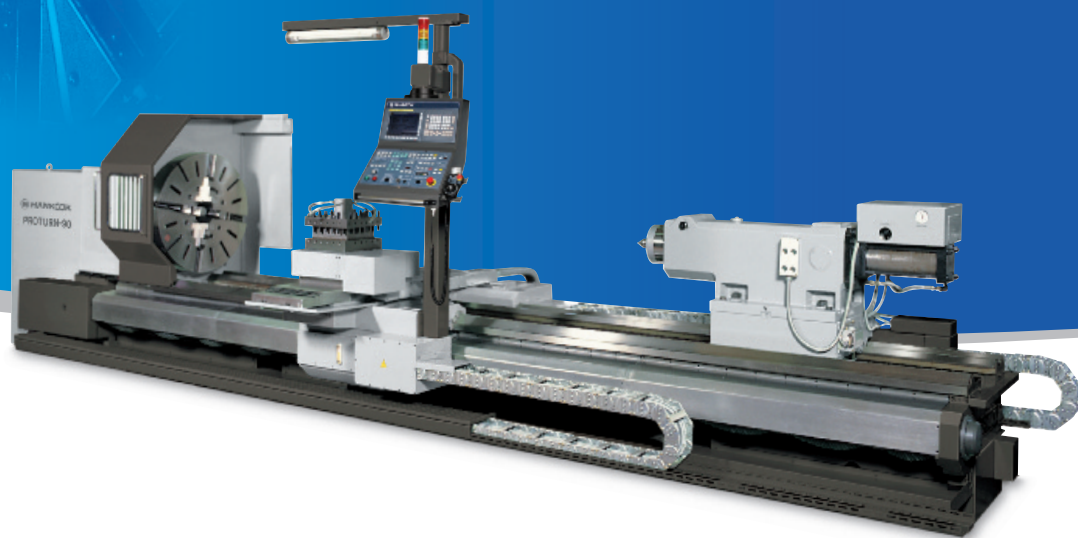



## Heavy Duty CNC Turning Lathes

# PROTURN 90/100

The Hankook Heavy Duty CNC Turning Lathe PROTURN 90/100s are Designed for Maximum Efficiency, Rigidity and Versatility in Heavy Machining Operations.

### Features

- Automatic 3 speed geared headstock
- Swing up to  $\varnothing$ 1000mm and 8000mm shaft turning capacity
- 1800 rpm spindle
- Powerful 50 horsepower spindle motor
- Extra wide (710mm) one-piece cast iron bed
- Induction-hardened and precision-ground guide ways
- Built-in tailstock spindle ( $\varnothing$ 200mm quill dia.)
- Heavy duty bi-directional H-4 turret
- Full automatic lubrication to all critical areas
- Full length rear chip guard and single front door (Optional)



### ■ Main Spindle

The rigid main spindle is made of forged Chrome Molybdenum steel.

All spindle bearings are high precision class and are permanently grease lubricated and sealed for maximum performance.

The main spindle delivers up to 522kgf.m of torque.

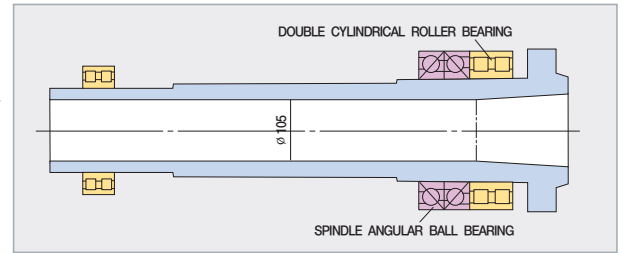

### ■ Headstock

The robust box type 3-speed geared headstock guarantees unsurpassed stability and smooth machining throughout the entire range of speed and load conditions.

All gears and shafts are made of special alloy steel.

They are induction hardened, precision ground and then balanced at high speed for maximum performance.

The high volume forced lubrication system maximizes service life of both drive gears and drive shaft bearings

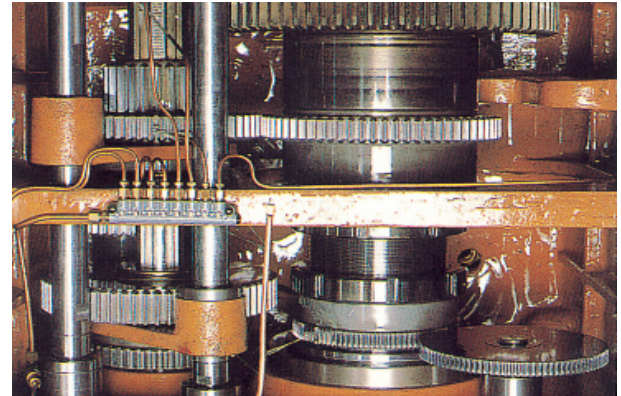

### ■ Bed

The extra wide(710mm) bed is a heavy one-piece casting and is heavily ribbed to prevent twisting and deformation. Fine grain Meehanite cast iron is used for its excellent dampening characteristics. All guide-ways are induction hardened and precision ground in one set up. Chips are easily disposed through steep angle chutes provided in between bed ways.

The flat bed design is ideal for heavy shafts as the weight of the work-piece is directed downward onto the bed ways.

The bed ways are double "V" type to ensure superior machining accuracy.

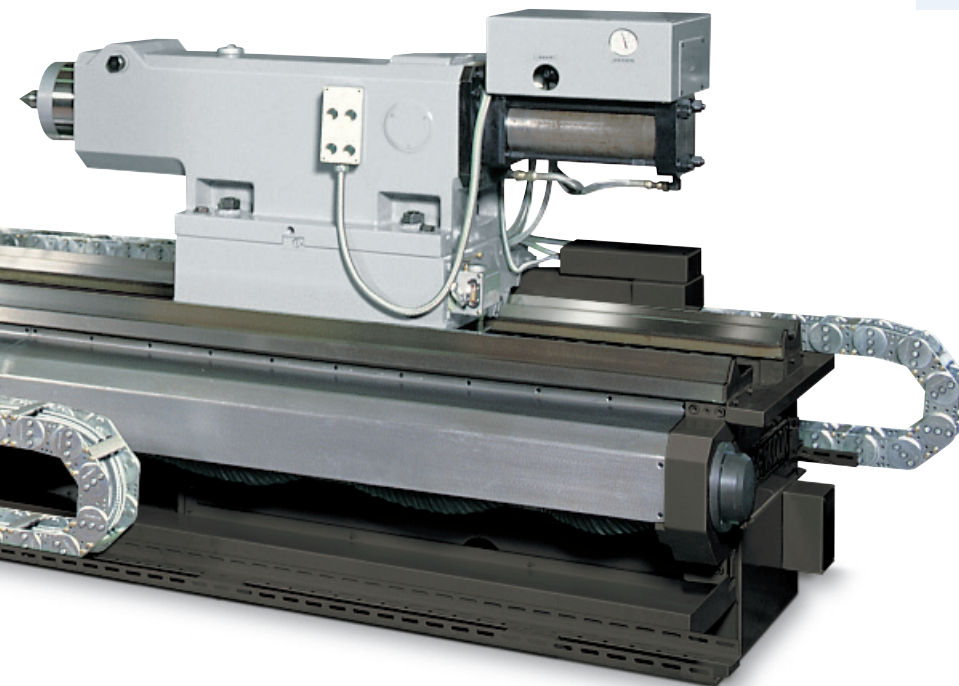
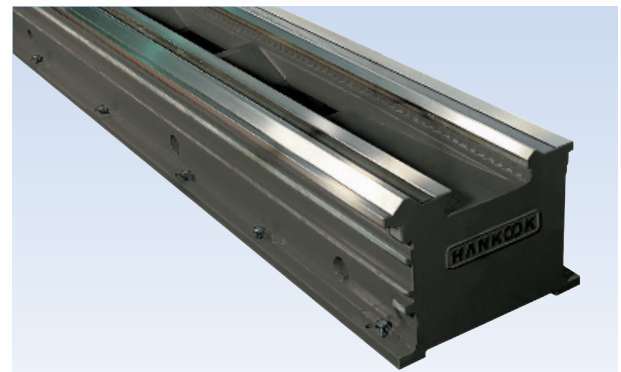

### ■ Spindle Torque

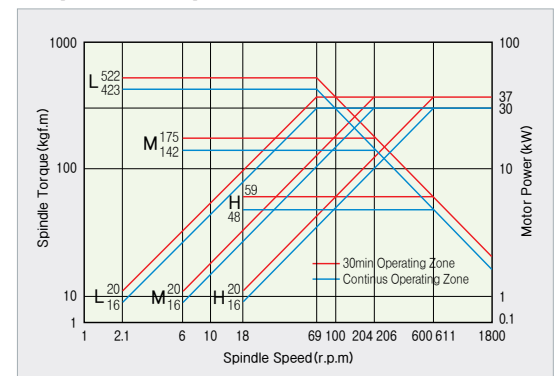

## Carriage & Turret Tool Post

The extremely rigid extended H-style saddle and wide cross slide allow heavy and interrupted cuts with ultimate stability and high accuracy. Floroplastic resin is bonded to the sliding surfaces and then hand scraped for a perfect match.

The floroplastic resin combined with fully automatic metered way lubrication provides a low friction surface and virtually eliminates guide-way wear.

The fully automatic horizontal 4-station turret tool post features bi-directional indexing. The large diameter(320mm) Curvic couplings and the powerful hydraulic clamping force(4200kgf) of this heavy duty turret tool post insure unmatched metal removal rate, extended tool life and superb finish and accuracy. Vertical 8-station turret as any combination of dual turret configurations is available as an option. Vertical 8-station power tool turret, special milling unit with manual Y-axis, or deep hole boring device is also available as an option.

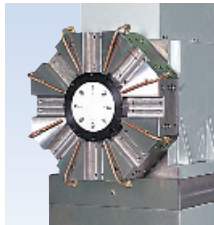
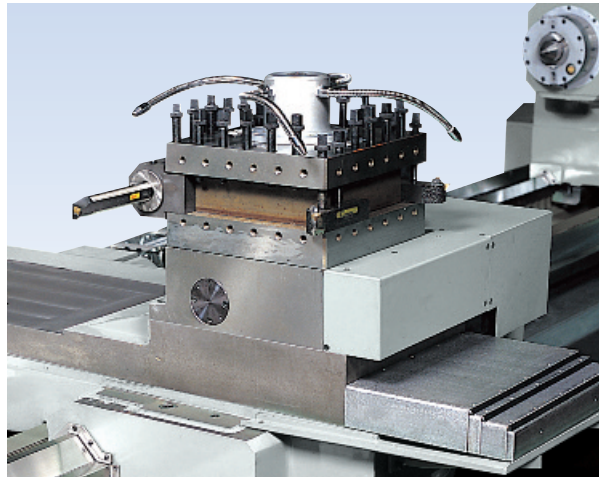

V8 Turret

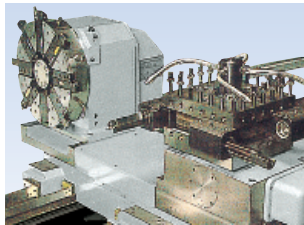

H4+V8 Double Turret

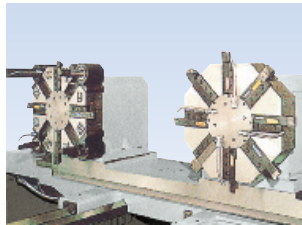

V8+V8 Double Turret



Milling Unit

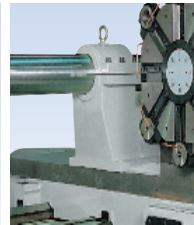

Boring Bar Device

## Tailstock

The heavy duty box type tailstock combined with a large diameter(200mm) heavy duty quill and built-in rotating spindle with MT #6 taper assures maximum stability and accuracy even under 8 tons of weight loaded between enters.

All tailstock spindle bearings are high precision class.

The hydraulic tailstock load meter permits precise setting of quill thrust : work weight vs. thrust requirement chart provided at the tailstock.

Motorized rapid traverse device provided for fast positioning.

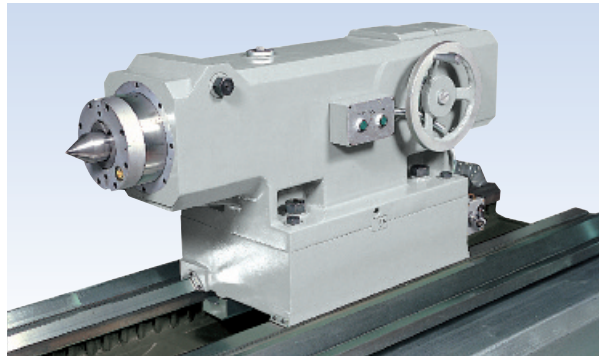

## Tool Travel Range

### H-4 Turret

Unit : mm

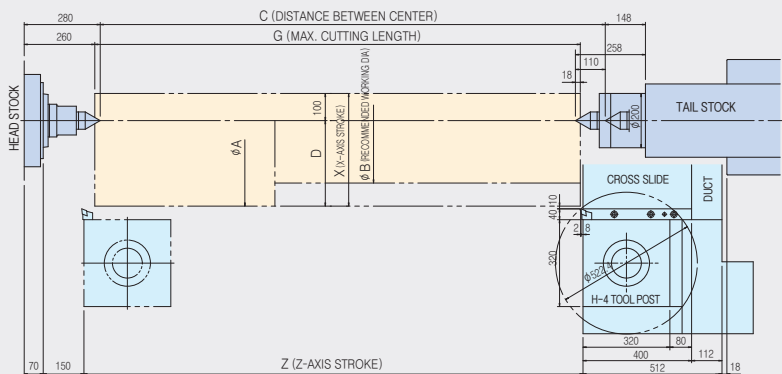

	A	B	D	X	Distance centers	2000	3000	4000	5000	6000	7000	8000
PROTURN-90	710	560	355	455	C	2187	3187	4187	5187	6187	7187	8187
PROTURN-100	800	660	400	500	G	2115	3115	4115	5115	6115	7115	8115
					Z	2165	3165	4165	5165	6165	7165	8165

### TOOL POST & TAIL STOCK INTERFERENCE

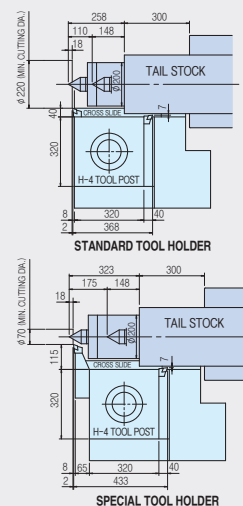

**Machine Specifications**

Items		Unit	PROTURN						
			90		100		90M		100M
Capacity	Swing over bed	mm(inch)	900(35.4)		1000(39.4)		900(35.4)		1000(39.4)
	Swing over cross slide	mm(inch)	560(22.0)		660(26.0)		560(22.0)		660(26.0)
	Max. turning diameter	mm(inch)	710(28.0)		800(31.5)		710(28.0)		800(31.5)
	Distance between centers	mm(inch)	2000(79)	3000(118)	4000(157)	5000(197)	6000(236)	7000(276)	8000(315)
	Max. turning length	mm(inch)	Same as center distance						
	Max. load between centers	kg(lbs)	8000(17600)						
Spindle	Spindle speed	rpm	2-1800						
	Spindle speed range	-	Automatic 3 steps						
	Spindle nose	ASA	A2-11						
	Spindle bore	mm(inch)	105(4.13)						
	Spindle taper	-	1/10 metric taper #120						
	Max. spindle torque	kgf.m(ftf.lb)	522(3744)						
C-axis	Max. speed	rpm	-				11.11		
	Max. torque	kgf.m(ftf.lb)	-				270(1952)		
Turret Tool Post	Standard tool post	-	Automatic H-4 Turret						
	Cutting tool size(O.D/I.D)	mm(inch)	□32/Ø63 (□11/4/Ø2.5)						
	Curvic coupling diameter	mm(inch)	320(12.6)						
	Turret clamping force	kgf(lbs)	4200(9260)						
Travel	X-axis travel	mm(inch)	465(18.3)		510(20.1)		465(18.3)		510(20.1)
	Z-axis travel	mm(inch)	2165(85.2)	3165(124.6)	4165(163.9)	5165(203.3)	6195(243.9)	7195(283.3)	8198(322.6)
	X-axis rapid traverse	mm(ipm)	6(236)				4(160)		
	Z-axis rapid traverse	mm(ipm)	9(350)		6(236)		4(160)		
Tailstock	Quill diameter	mm(inch)	200(7.87)						
	Quill type	-	Built-in live spindle						
	Spindle taper	-	MT #6						
	Max. quill travel	mm(inch)	250(9.87)						
Motor	Spindle motor	kW(Hp)	AC 30/37(40/50)						
	X-axis servo motor	kW(Hp)	AC 3(4)						
	Z-axis servo moto	kW(Hp)	AC 7(9.4)						
	C-axis servo motor	kW(Hp)	-				AC 4(5.4)		
Bed	Bed width	mm(inch)	710(28)						
	Bed height	mm(inch)	600(24)						
Machine weight	PROTURN-90	kg(lbs)	9300 (20500)	10100 (22300)	10900 (24000)	11700 (25800)	12500 (27600)	13300 (29300)	14100 (31100)
	PROTURN-100		Add. 120(265)						

**Standard Accessories**

- CNC controller, FANUC Oi series
- Spindle motor & electrical equipments
- 4-jaw independent chuck, 24”(Ø600mm)
- C-axis system, 90M/100M only
- Automatic index turret (Hydraulic H-4)
- Coolant system
- Rotary tailstock spindle
- Rapid feed device for tailstock
- Tailstock load-meter (6-ton)
- Hydraulic power unit
- Automatic lubrication system for guides
- Center sleeve
- Center (for haedstock and tailstock)
- Patrol lamp & work light
- Chuck cover
- OD turning tool holder ( 1 )
- Boring tool holder (Ø63mm)
- Boring bar sleeve (Ø63×50, 40mm)
- Drill sleeve (Ø63×MT#4, #3)
- Levelling blocks, foundation bolts & nuts
- Tool box with maintenance tools

**Optional Accessories**

- Hydraulic chucks
- 4-jaw independent chuck, Ø24”, Ø28”, Ø32”
- Face plate (Ø800mm)
- Steady rest, roller jaws (Ø50-250, Ø250-450, Ø450-650mm)
- Steady rest, metal jaw (Ø50-250, Ø250-450, Ø450-650mm)
- Follow rest, metal jaws (Ø20-200mm)
- Roll chock stand (Ø400-630mm)
- Hyd. automatic turret (V-8, H-4+H-4, H-4+V-8)
- Turn-mill turret (Electric V-8M, V-12M), Only for 90M/100M
- Milling unit, Only 90M/100M
- OD turning tool holder ( 1 )
- Boring tool holder (Ø63mm)
- Boring bar sleeve (Ø63×50, 40, 32, 25, 16mm)
- Drill sleeve (Ø63×MT#4, #3, #2, #1)
- Boring bar device (Bar excluded Ø100, Ø150mm)
- Tailstock load-meter (6, 8, 10 ton)
- Hyd. tailstock spindle (Only for Quill in & out )
- Chip conveyor & bucket
- Transformer
- Rear side full splash guard & single front door

## ■ Standard CNC Controller Features

### FANUC 0i Series Control Features

- Simultaneously controlled axes : 2
- Minimum programmable increment : 0.001mm(0.00001")
- Part program storage size : 2Mbyte
- Number of registerable programs : Max.1000
- Backlash compensation
- Interpolation type pitch error compensation
- Constant surface speed control
- Self-diagnostic functions

### Programming Features

- Circular interpolation
- Tool radius/Tool nose radius compensation
- Absolute/Incremental programming : Combined use in the same block
- Inch/Metric conversion
- Chamfering/Corner R
- Multiple repetitive cycles
- Canned cycles
- Decimal point programming
- Reference position return (G28)
- Sub program call : 10 holds nested

### Operation Features

- 10.4" color LCD
- Tool geometry/Wear compensation
- Tool offset pairs : 128 pairs
- Run hour and parts count display
- Thread cutting retract
- Direct input of tool offset value measured
- Keyboard type manual data input (MDI full key)
- Program protect
- Incremental feed
- Rapid traverse override
- Feedrate override
- Spindle override
- Program code : EIA/ISO

## ■ External Dimensions

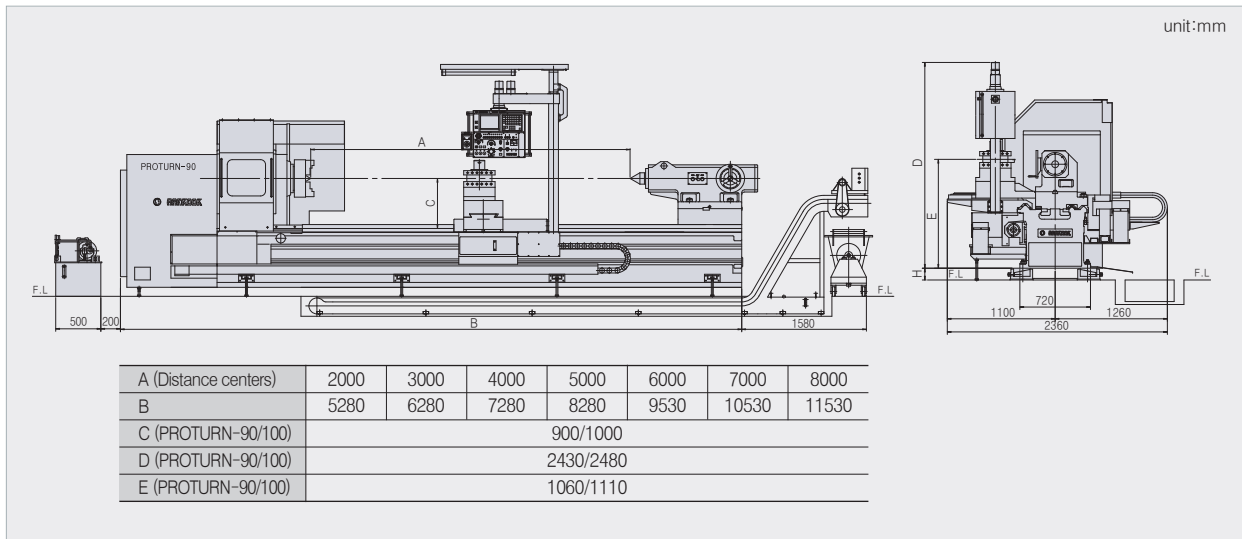

Note : Specifications and features are subject to change without prior notice.



**HANKOOK**

HANKOOK MACHINE TOOLS CO.,LTD.

HEAD OFFICE & PLANT

**HANKOOK MACHINE TOOLS CO., LTD.**

80-1, Jangbang-ro, Hallim-myeon, Gimhae-si,

Gyeongsangnam-do, 50849 Korea

TEL : +82-55-282-7781 FAX : +82-55-342-9771

E-mail : hansale@hanmachine.com

[www.hanmachine.com](http://www.hanmachine.com)

AMERICA OFFICE

**Hankook America, Corp.**

1601 Atlantic Drive-#109 West Chicago, IL 60185, U.S.A

TEL : +1-630-562-9240 FAX : +1-630-562-9250

E-mail : [info@hankookamerica.com](mailto:info@hankookamerica.com)

NA09-B06E Printed in Korea 2022.10